

INSTRUCTION MANUAL

1/10 Scale 4WD RC Nitro & Electric Powered Car



Rattlesnake

Rh1041 Rattlesnake N1(1speed)
RH1042 Rattlesnake N2(2speed)
RH1039 Rattlesnake EBD(Brushed)
RH1040 Rattlesnake EBL(Brushless)



COYOTE

Rh1037 Coyote N1(1speed)
RH1038 Coyote N2(2speed)
RH1035 Coyote EBD(Brushed)
RH1036 Coyote EBL(Brushless)

Index

Rattlesnake/Coyote Nitro Specification-----	P2
Assembly Diagrams-----	P3-P6
Shocks & Chassis Assembly-----	P3
Front & Rear Assembly-----	P4
Engine & Central Trasmssion Assembly-----	P5
Other nitro assemblies-----	P6
Assembly Steps-----	P7
Rattlesnake/Coyote Electric Specification-----	P8
Assembly Diagrams-----	P9
Assembly Steps-----	P10
Part List-----	P11-P19
Part List-----	P11-P18
Upgrade Part List-----	P19

Rattlesnake/Coyote Nitro Version

Rattlesnake N1 /Coyote N1(single speed)

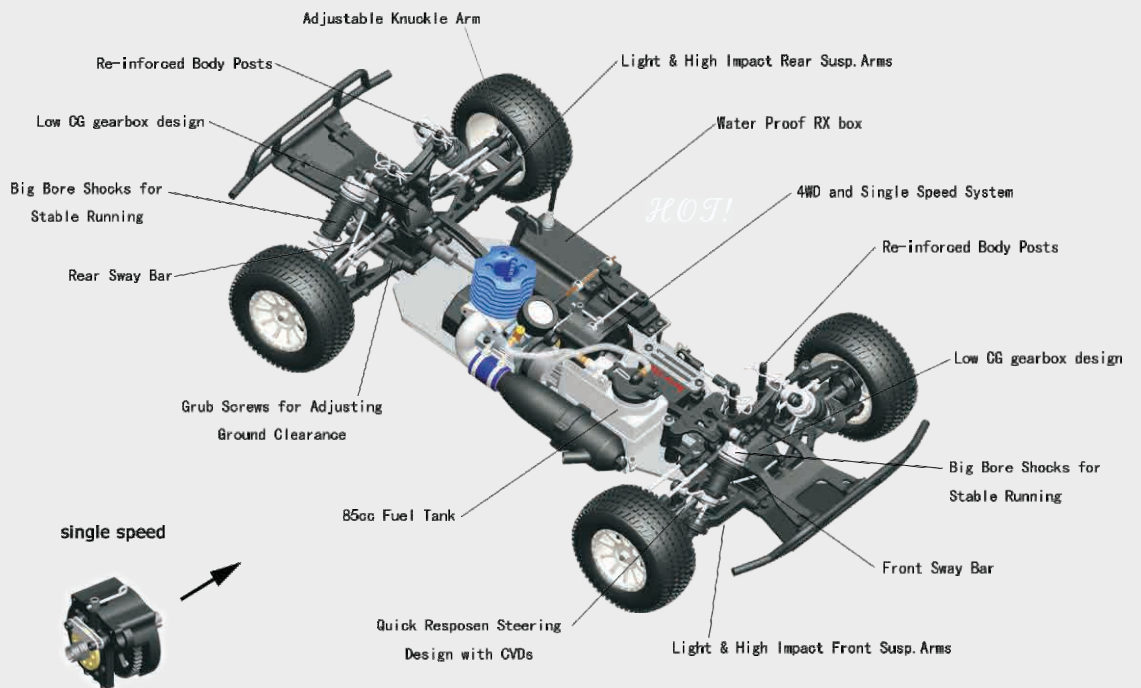

Spec.:

Length: 530mm
 Width: 290mm
 Wheelbase: 325mm
 Gear ratio: 9.1:1
 Tire: 95*40mm

Rattlesnake N2 /Coyote N2(2 s speed)

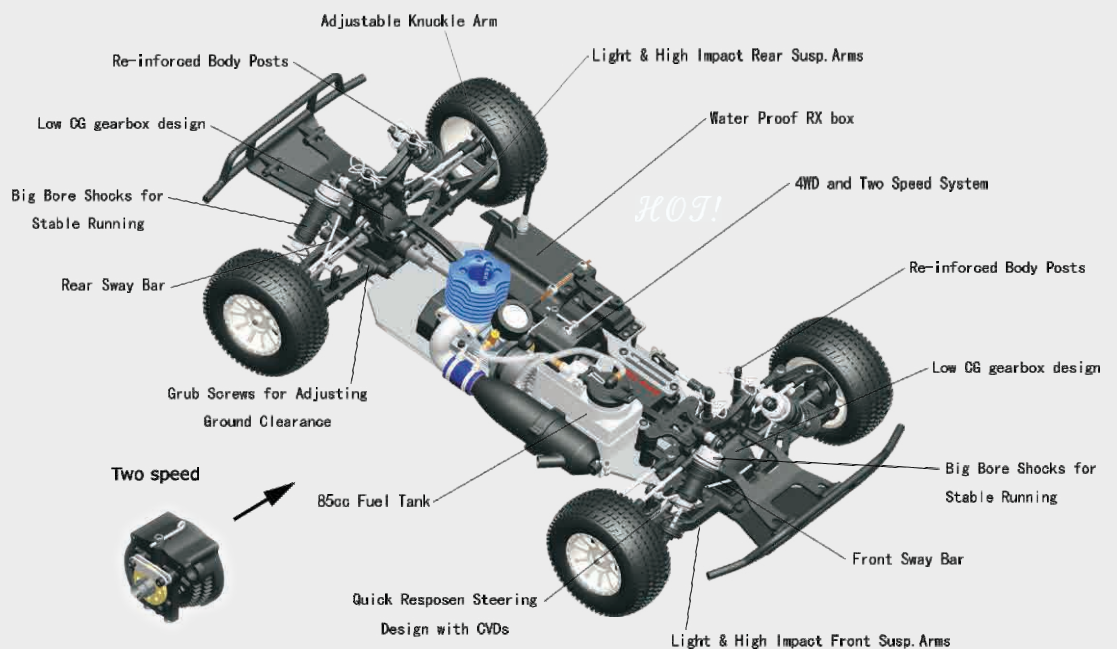

Spec.:

Length: 530mm
 Width: 290mm
 Wheelbase: 325mm
 Gear ratio: 9.1:1(L);
 6.1:1(H)
 Tire: 95*40mm

Front Shocks

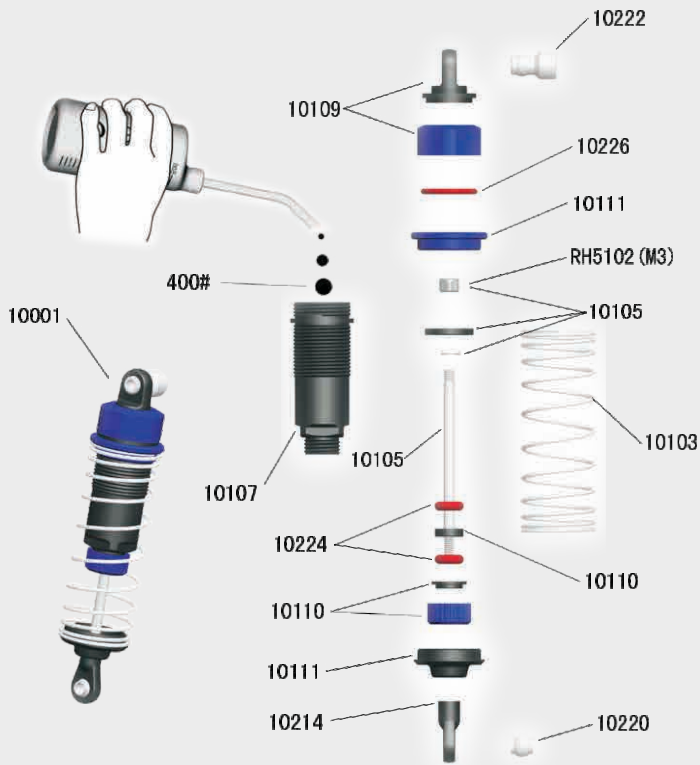

(Dia. 3-1)

Rear Shocks

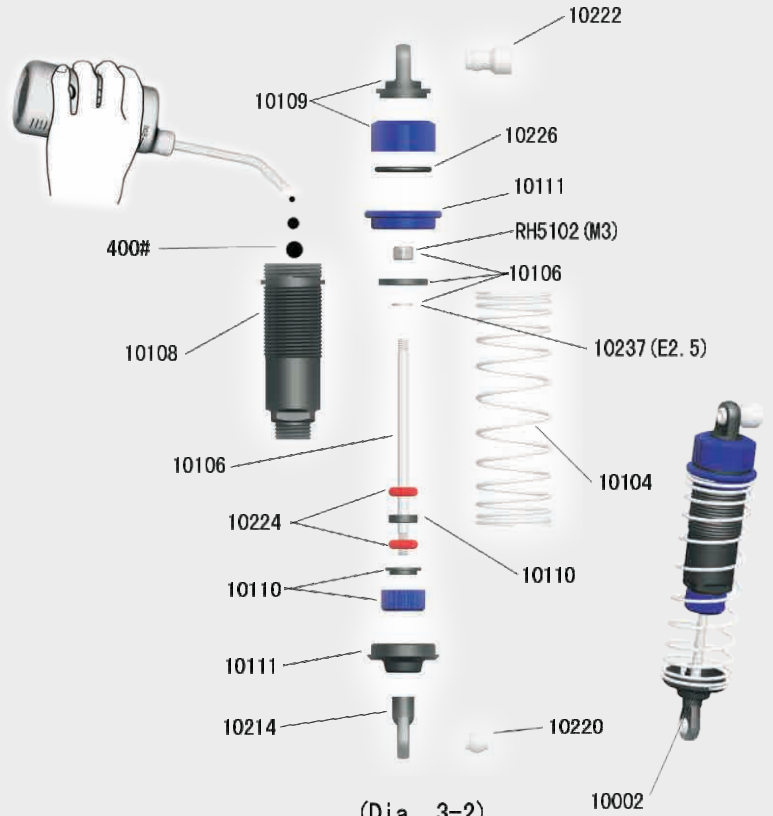

(Dia. 3-2)

Chassis Assembly

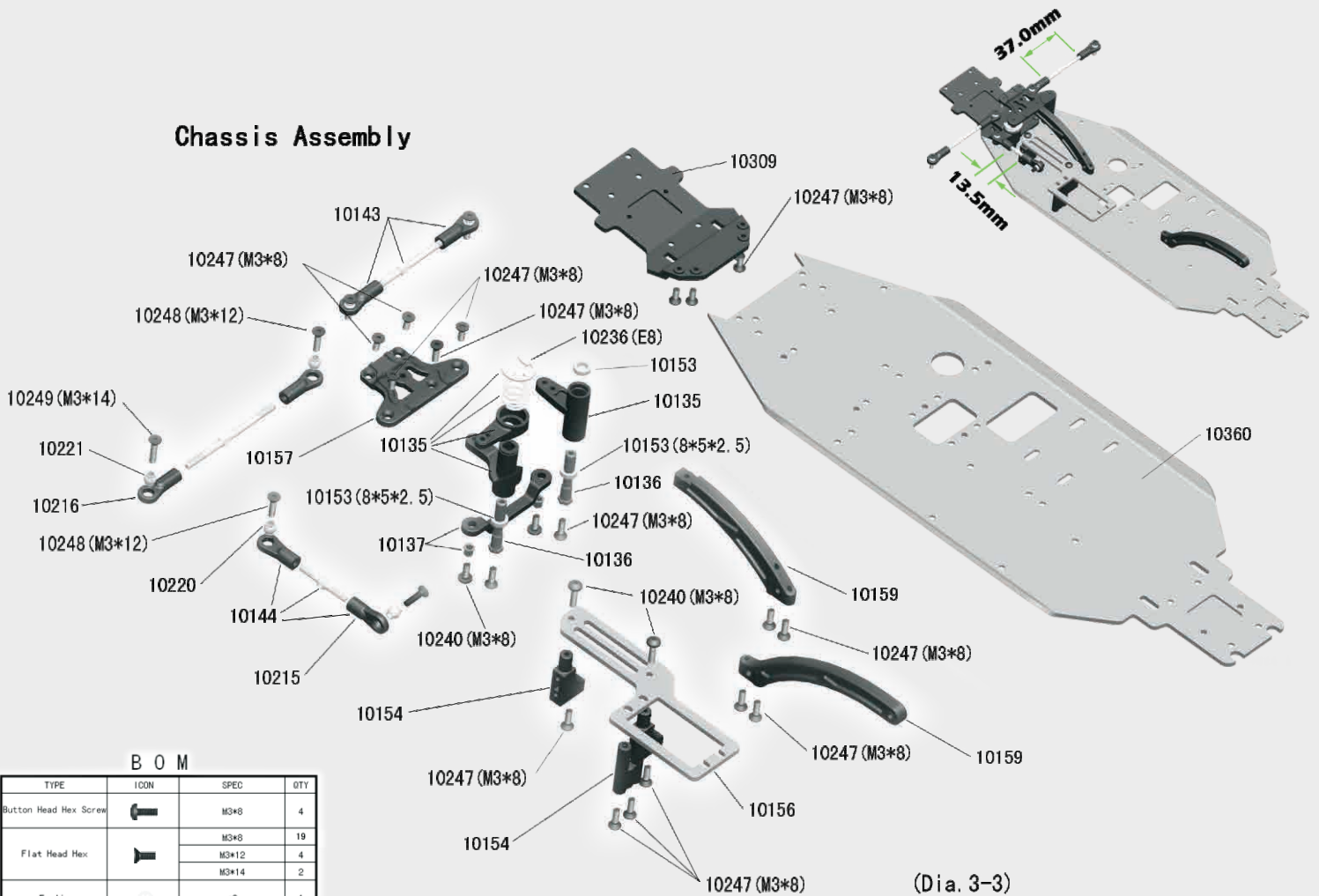

(Dia. 3-3)

B O M

TYPE	ICON	SPEC	QTY
Button Head Hex Screw		M3*8	4
		M3*8	19
		M3*12	4
Flat Head Hex		M3*12	4
		M3*14	2
E clip		ø8	1
Ball Bearing		ø8*ø5*2.5	3

Front Assembly

B O M

TYPE	ICON	SPEC	QTY
Round Head Self Tapping Hex Screw		2*10	4
Button Head Hex Screw		3*6	4
		M3*6	3
		M3*12	2
		M3*6	4
		M3*14	2
Cap Head Hex Screw		M3*16	2
		M3*18	2
		M3*6	2
		M3*10	10
		M3*12	3
		M3*14	2
		M3*20	2
Flat Head Hex		M3*10	10
		M3*12	3
		M3*14	2
		M3*15	2
		M3*20	2
Set Screw		M3*3	2
		M4*4	1
		M4*10	2
		M3*3	2
Ring Self Tapping Screw		3*4	2
Washer		ø6*3.1*0.2	2
Nylon Lock Nut		M3	2
E clip		ø2.5	5
O'Ring		ø6.05*ø4.55*ø1.55	4
Ball Bearing		ø15.6*ø12.6*ø1.5	4
		ø15*ø10*4	2
		ø10*ø5*4	6

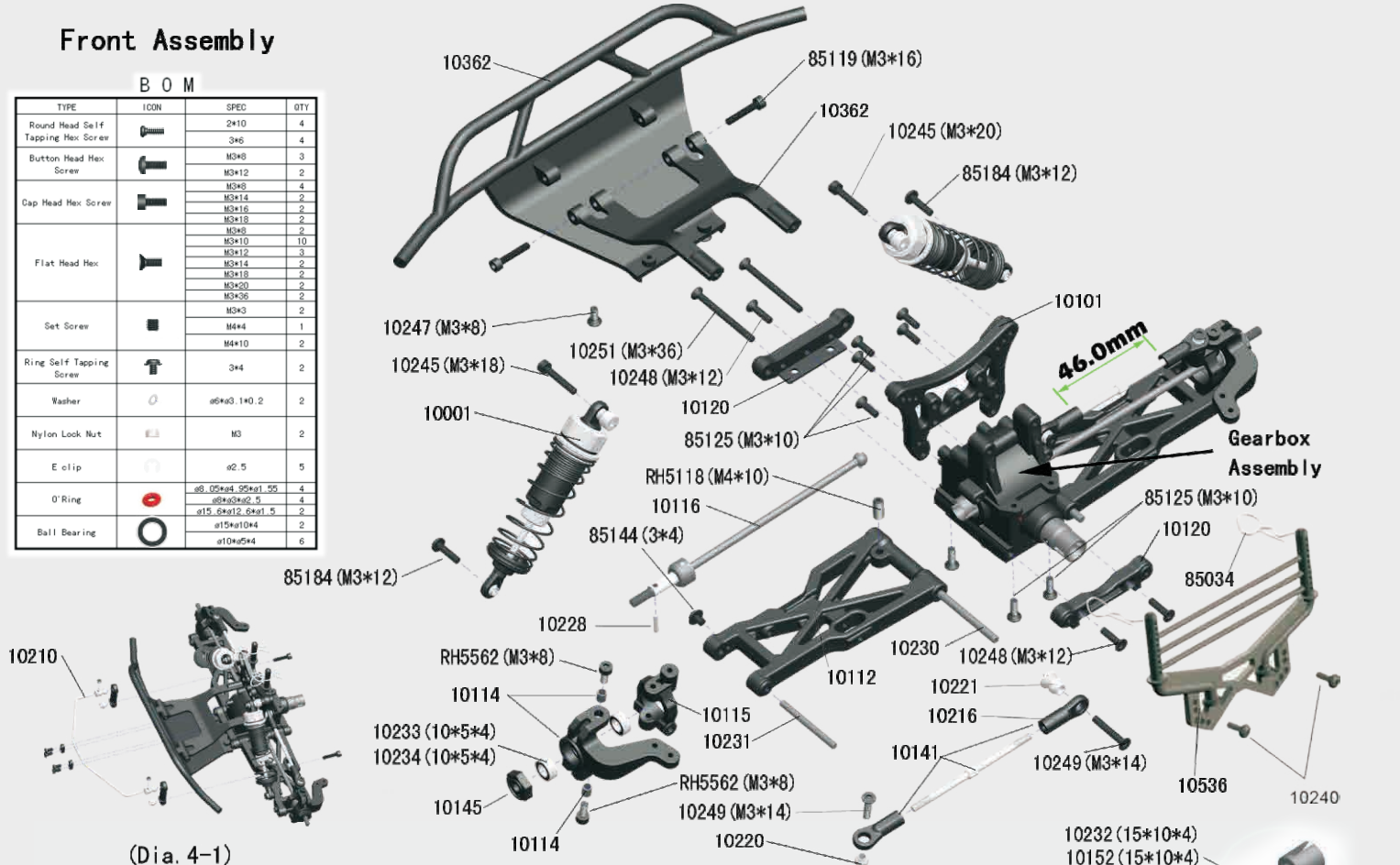

(Dia. 4-1)

Gearbox Assembly

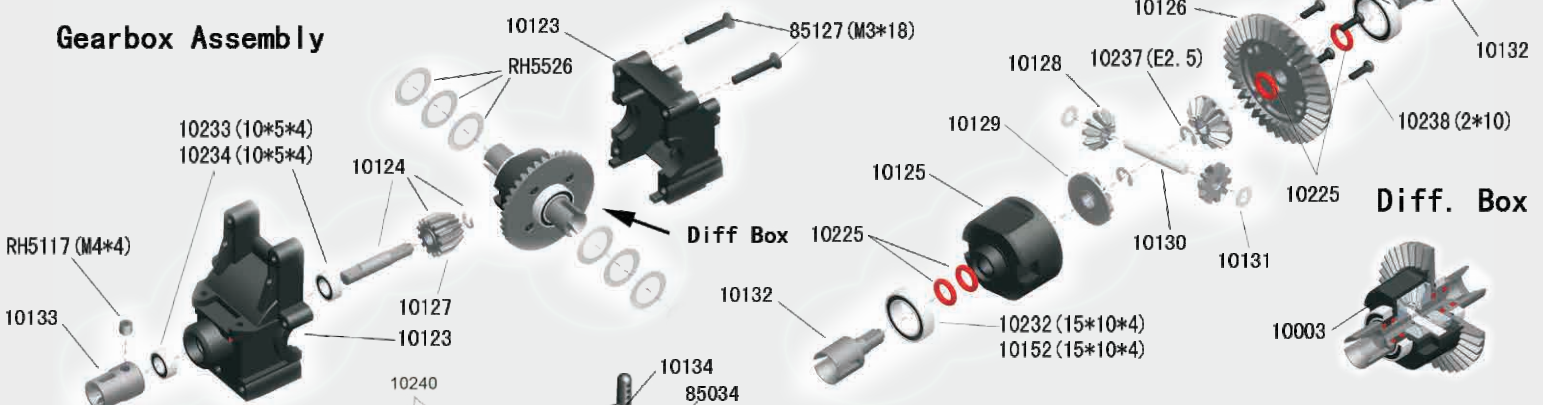

(Dia. 4-2)

Rear Assmeby

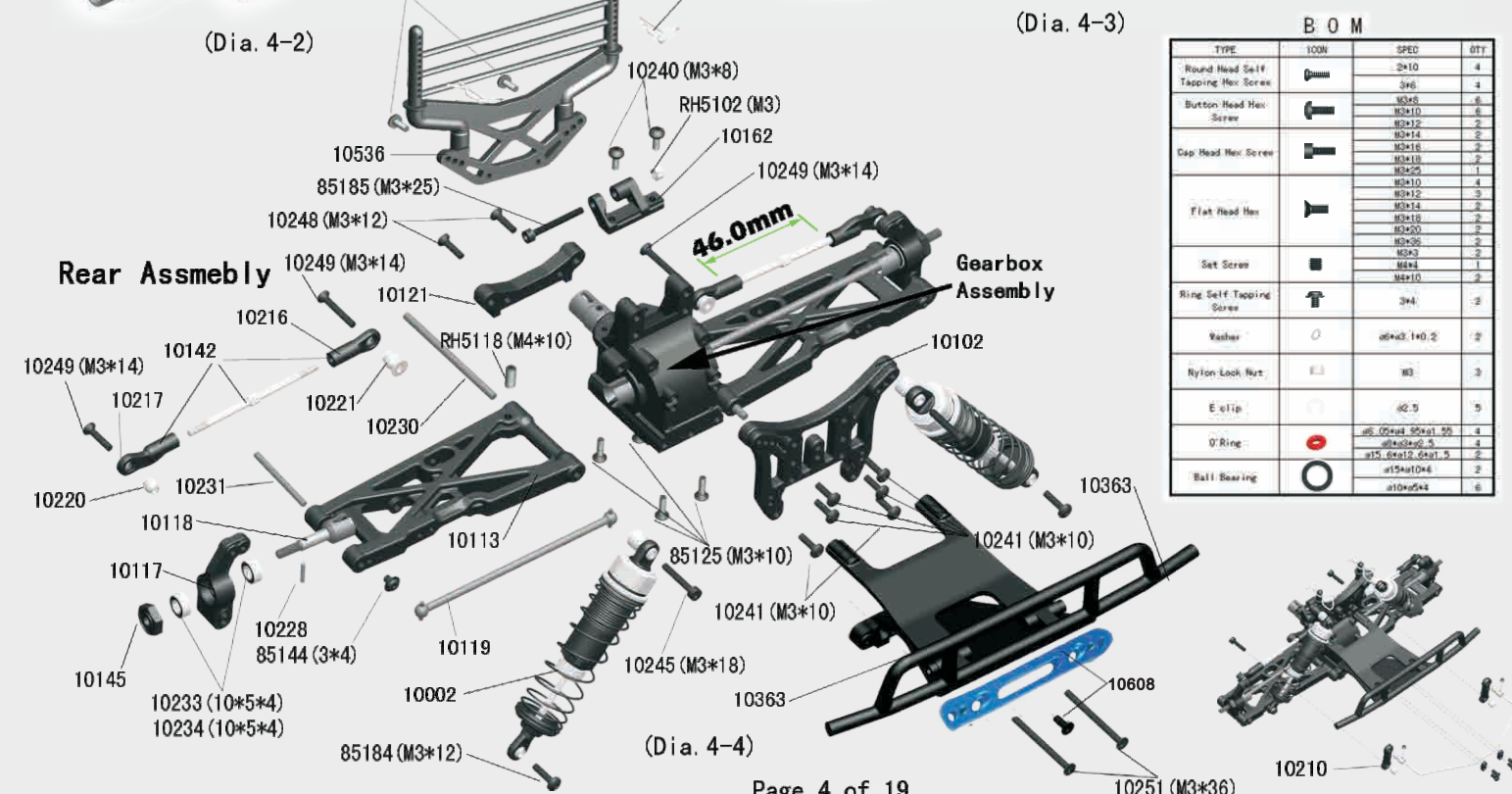

(Dia. 4-4)

Diff. Box

B O M

TYPE	ICON	SPEC	QTY
Round Head Self Tapping Hex Screw		2*10	4
Button Head Hex Screw		3*6	4
		M3*6	3
		M3*10	2
		M3*12	2
		M3*14	2
Cap Head Hex Screw		M3*16	2
		M3*18	2
		M3*6	2
		M3*10	10
		M3*12	3
		M3*14	2
		M3*20	2
Flat Head Hex		M3*10	10
		M3*12	3
		M3*14	2
		M3*15	2
		M3*20	2
Set Screw		M3*3	2
		M4*4	1
		M4*10	2
		M3*3	2
Ring Self Tapping Screw		3*4	2
Washer		ø6*3.1*0.2	2
Nylon Lock Nut		M3	3
E clip		ø2.5	5
O'Ring		ø6.05*ø4.55*ø1.55	4
Ball Bearing		ø15.6*ø12.6*ø1.5	4
		ø15*ø10*4	2
		ø10*ø5*4	6

(Dia. 4-3)

B O M

TYPE	ICON	SPEC	QTY
Round Head Self Tapping Hex Screw		2*6	4
Button Head Hex Screw		M3*8	4
Cap Head Hex Screw		M3*15	2
		M3*26	5
Flat Head Hex		M3*10	1
Set Screw		M4*4	1
Washer		ø6*ø3.1*ø0.2	1
Nylon Lock Nut		M3	5
O'Ring		ø31* ø2	1
Ball Bearing		ø10*ø5*4	2

Engine Assembly

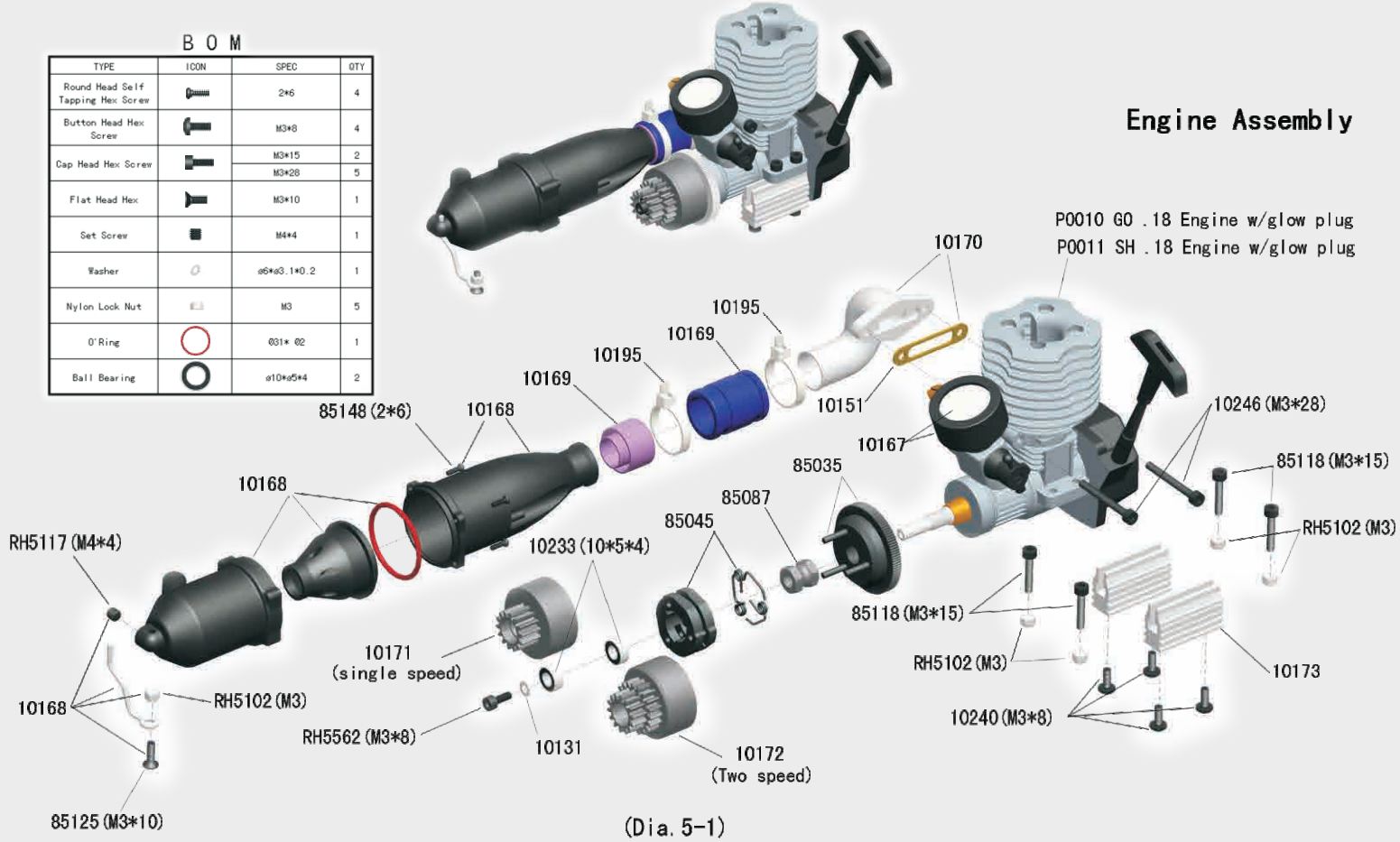

Rattlesnake/Coyote N1 Central Transmission

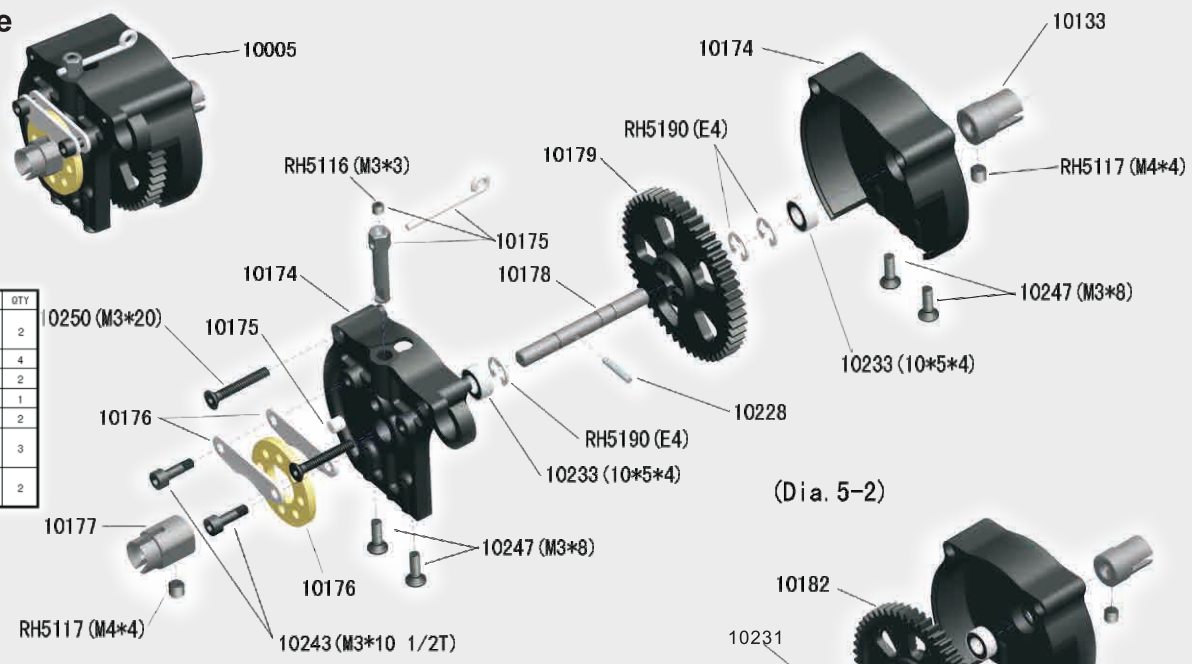

B O M

TYPE	ICON	SPEC	QTY
Cap Head Hex Screw		M3*10	2
Flat Head Hex		M3*8	4
		M3*20	2
Set Screw		M3*3	1
		M4*4	2
E clip		ø4	3
Ball Bearing		ø10*ø5*4	2

Rattlesnake/Coyote N2 Central Transmission

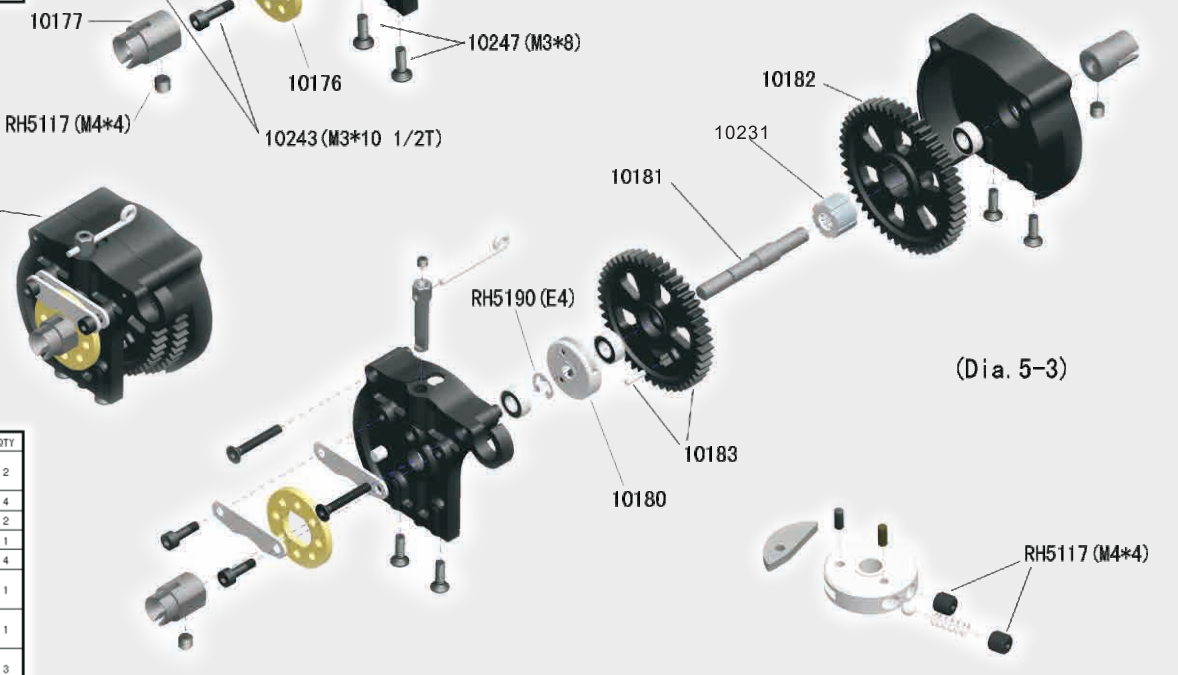

B O M

TYPE	ICON	SPEC	QTY
Cap Head Hex Screw		M3*10	2
Flat Head Hex		M3*8	4
		M3*20	2
Set Screw		M3*3	1
		M4*4	4
E clip		ø4	1
One Way Bearing		ø12*ø6.3*ø8.4	1
Ball Bearing		ø10*ø5*4	3

Assembly Steps:

1. Fasten the fuel tank posts to the chassis, then the fuel tank assembly. (See Dia. 6-6)

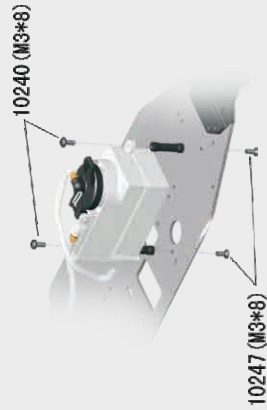

2. Assemble Chassis. (See Dia. 3-3, 6-1, 6-2)

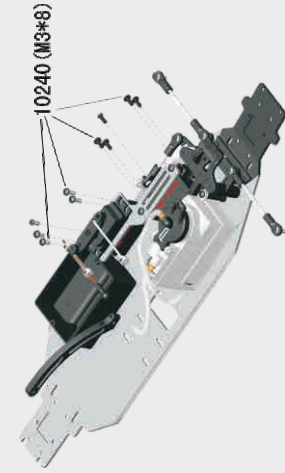

3. Assemble the front assembly to the chassis. (See Dia. 4-1)



4. Assemble the rear assembly to the chassis. (See Dia. 4-4)



5. Tighten the wheels. (See Dia. 6-4 or 6-5)



6. Assemble central transmission and rear central drive shaft to the chassis. (See Dia. 5-2 or 5-3)

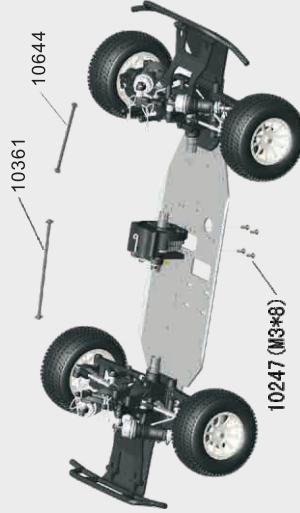

7. Tighten the engine assembly to the chassis. (See Dia. 5-1)

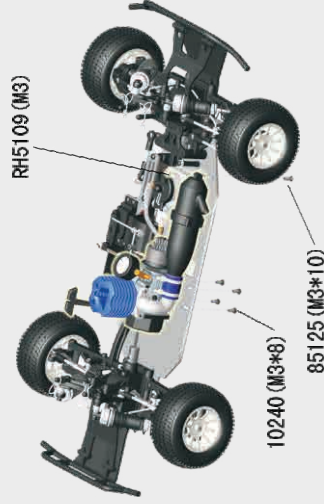

8. Finally connect battery, receiver and setup the electronics functions, then screw the receiver cover and put on the body. (See Dia. 6-3)

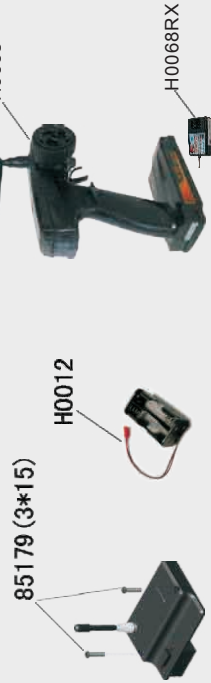

Note: Cut the plastic bars to fix the bodies.

When use body R0187, add alum body posts on rear body mount to meet the body height.

Rattlesnake/Coyote EBD(Brushed)

Rattlesnake/Coyote EBL(Brushless)

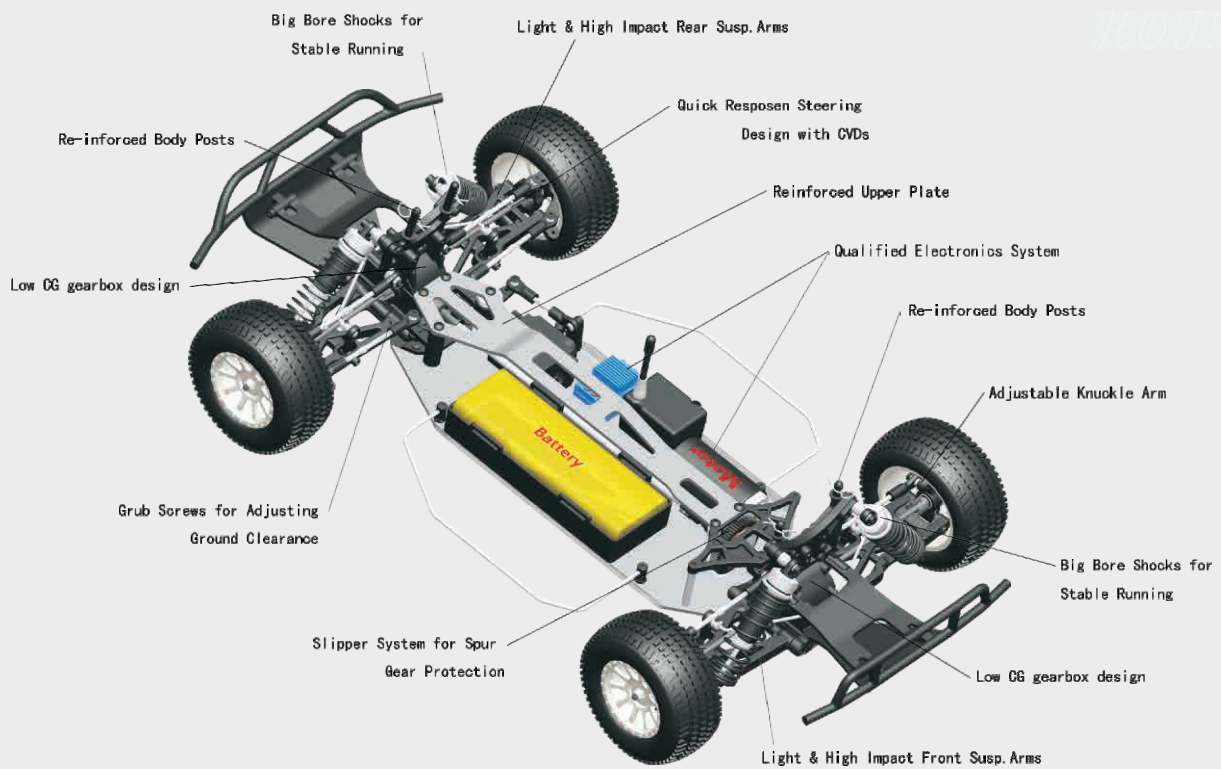

Spec.:

Length: 530mm
 Width: 290mm
 Wheelbase: 325mm
 Gear ratio: 8.3:1
 Tire: 95*40mm

Standard Equipments :

Steering Servo: 3kg/cm
 Motor: 550(EBD); 3650-3000KV(EBL)
 ESC: 40A(EBD); 45A(EBL)
 Battery: Ni-MH SC1800mAH(EBD)
 Lipo 3250mAH 7.4V <25C(EBL)
 Radio: 2.4GHz

ASSEMBLY STEPS:

1, Assemble center chassis part.
(See Dia. 9-1)

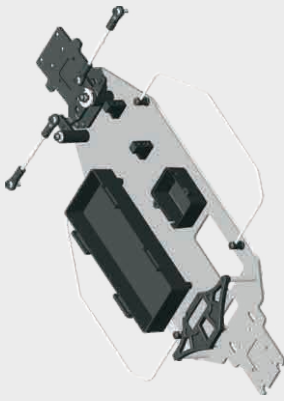

2, Assemble front assembly to chassis front. (See Dia. 4-1)

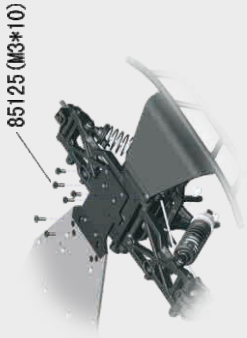

3, Assemble rear assembly to chassis rear part. (See Dia. 4-4)



5, Mount the wheels.
(See Dia. 6-4, 6-5)



6, Mount the motor assembly and central drive shaft. (See Dia. 9-6)

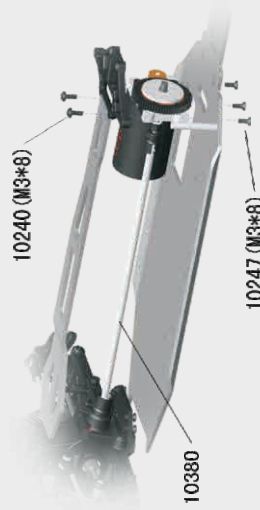

7, Assemble steering servo and linkage. (See Dia. 9-4)



8, Assemble ESC, receiver, battery and connect them to setup. (See Dia. 9-3, 9-5)

Note: Cut the plastic bars to fix the bodies.

Brushless System:

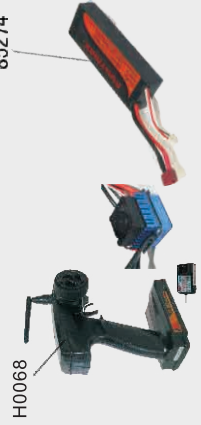



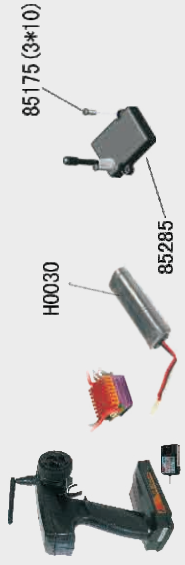









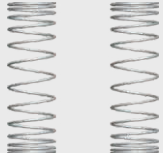





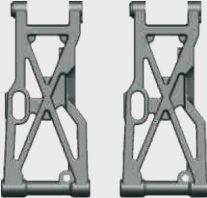

Brushed system:



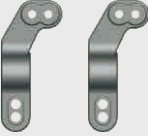

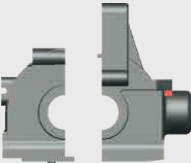





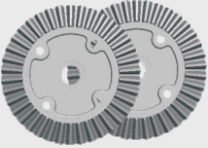

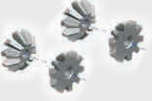





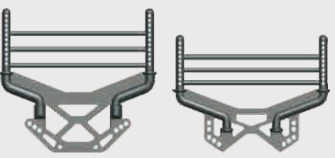

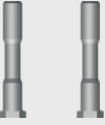

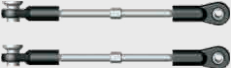

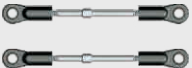
When use body R0187, add alum body posts on rear body mount to meet the body height.

Part List

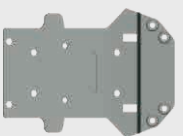
<p>10101 - Front Shock Tower 1pc</p> 	<p>10102 -Rear Shock Tower 1pc</p> 	<p>10001-Front Shocks 2pc</p> 	<p>10002 - Rear Shock Tower 2pc</p> 
<p>10103-Front Shock Spring 2pc</p> 	<p>10104-Rear Shock Spring 2pc</p> 	<p>10105-Front Shock Shaft & Piston Set 2sets</p> 	<p>10106-Rear Shock Shaft & Piston Set 2sets</p> 
<p>10107-Front Shock Body 2pc</p> 	<p>10108-Rear Shock body 2pc</p> 	<p>10109-Shock Upper Cap 2sets</p> 	<p>10110-Shock Lower Caps 2sets</p> 
<p>10111-Shock Lower holder & Adjust Ring 2sets</p> 	<p>10112-Front Lower Susp. Arm 2pc</p> 	<p>10113-Rear Lower Susp. Arm 2pc</p> 	<p>10114-Steering Knuckle Arm 1set</p> 
<p>10115-Uprights 2pc</p> 	<p>10116-Front CVD 2pc</p> 	<p>10117-Rear Hub Carrier 2pc</p> 	<p>10118-Rear Drive Shaft 2pc</p> 
<p>10119-Rear Dogbones 2pc</p> 	<p>10123-Gearbox Housing Set 2pcs</p> 	<p>RH5526-Diff 16T Gear Washer 6pcs</p> 	<p>10124-Diff.Drive Gear w/pin 2sets</p> 

Part List

<p>10125-Diff Case 2pcs</p> 	<p>10126-Diff Drive Spur Gear 2pcs</p> 	<p>10127-Diff Drive Gear 2pcs</p> 	<p>10128-Diff Bevel Gear S. 4pcs</p> 
<p>10129-Diff Bevel Gear B. 4pcs</p> 	<p>10130-Diff Pin 2pcs</p> 	<p>10131-Washer 6pcs</p> 	<p>10132-Diff Drive Cup 4pcs</p> 
<p>10133-Center Coupler 3pcs</p> 	<p>10536-Body mount front & rear</p> 	<p>10135-Servo Saver (GP) 1set</p> 	<p>10136-Servo Saver Post 2pcs</p> 
<p>10137-Steering Ackerman</p> 	<p>10141-Front Upper Susp. Arm 2sets</p> 	<p>10142-Rear Upper Susp. Arm 2sets</p> 	<p>10143-Steering Arm 2sets</p> 
<p>10144-Servo Linkage 1pc</p> 	<p>10145-Wheel Hub 4pcs</p> 	<p>10146-Antenna Pipe Set 2sets</p> 	<p>10147-Servo Saver (EP) 1set</p> 
<p>10330-Chassis Front Part 1pc</p> 	<p>10522-Tyre & insert 2sets</p> 	<p>10523-Wheel complete 2sets</p> 	<p>10524-Rim 2pcs</p> 

Part List

<p>10362-Front bumper Set 1set</p> 	<p>10363-Rear bumper Set 1set</p> 	<p>10003-Diff Gearbox Set 1set</p> 	<p>10607-Rear susp. arm pins w/screws</p> 
<p>10151-Manifold Gasket 6pc</p> 	<p>10152-Metal Bushing 15*10*4 6pc</p> 	<p>10153-Metal Bushing 8*5*2.5 6pc</p> 	<p>10154-Servo & Upper Plate Mounts 1set</p> 
<p>10156-Upper Plate 1pc</p> 	<p>10157-Upper Steering Plate</p> 	<p>10004-Fuel tank Set 1set</p> 	<p>10158-Fuel Line 2pcs</p> 
<p>10159-Front/Rear Chassis Brace</p> 	<p>10160-Receiver Box 1set</p> 	<p>85026-Switch Cover 2pcs</p> 	<p>10161-Servo Horns</p> 
<p>10162-Chassis Brace mount 1pc</p> 	<p>10163-Stopper 6pcs</p> 	<p>10164-Throttle Linkage 1set</p> 	<p>10644-Central Dongbone F. 1pc</p> 
<p>P0010-GO. 18 engine 1pc P0011-SH. 18 Engine 1pc</p> 	<p>10167-Air filter 1Set</p> 	<p>10168-Tuned Pipe 1Set</p> 	<p>10169-Silicone Coupler 1Set</p> 



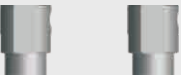















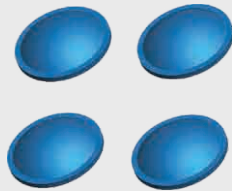



Part List

<p>85195-Zip Tie 6pcs</p> 	<p>10170-Manifold 1Set</p> 	<p>85035-Flywheel 1pc</p> 	<p>85087-Clutch Nut 2pcs</p> 
<p>85045-Clutch Shoes & Springs</p> 	<p>10171-Clutch Bell (14T) 1pc</p> 	<p>10172-Clutch Bell (two speed) 1pc</p> 	<p>10173-Engine mount 2pcs</p> 
<p>10005-Central Transmission Complete 1Set (Single Speed)</p> 	<p>10174-Central Transmission Bulkheads 2pcs</p> 	<p>10175-Brake Post 1Set</p> 	<p>10176-Brake Set 1set</p> 
<p>10177-Brake Cup 2pcs</p> 	<p>10178-Single Speed Shaft w/pin</p> 	<p>10179-50T Gear (Single Speed) 1pc</p> 	<p>10006-Central Transmission Complete 1Set (Two Speed)</p> 
<p>10180-Two Speed Clutch 1Set</p> 	<p>10181-Two Speed Shaft 1pc</p> 	<p>10182-50T Two Speed Gear 1pc</p> 	<p>10183-45T Two Speed Gear 1pc</p> 
<p>10360-N1/N2 Chassis Plate 1pc</p> 	<p>10361-Central Dongbone R. 1pc</p> 	<p>85286-Velcro Tape 2pcs</p> 	<p>10366-Servo post 2pcs</p> 





















Part List

<p>10189-Post for Rear Spur Gear Cover 2pc</p> 	<p>10190-Motor Mount (EP) 1pc</p> 	<p>10191-Slipper Complete (EP) 1set</p> 	<p>10192-Slipper Pad (EP) 2pc</p> 
<p>10193-Slipper Gasket (EP) 2pc</p> 	<p>10194-65T Spur Gear (EP) 1pc</p> 	<p>10195P- Slipper Shaft (EP) 1pc</p> 	<p>10196-Slipper Spring Bracket (EP) 1pc</p> 
<p>10197-Slipper Spring (EP) 1pc</p> 	<p>10199-Slipper Drive Cup 1pc</p> 	<p>10200-BEARING BRACKET (EP) 1pc</p> 	<p>10201-Pinion Gear 17T (EP) 1pc</p> 
<p>10608-Rear bumper fix plate w/screw</p> 	<p>10210-Sway Bar 2Sets</p> 	<p>10364-Body guard frame 2pcs</p> 	<p>10365-Body guard frame bracket 4pc</p> 
<p>10380-Certer Drive Shaft (EP) 1pc</p> 	<p>10381-EBD/EBL chassis plate 1pc</p> 	<p>10382-EBD/EBL upper plate 1pc</p> 	<p>85034-Body Clip (Medium Size) 6pcs</p> 
<p>85029-Body Clip (Small Size) 6pcs</p> 	<p>10214-Shock Ball End 6pcs</p> 	<p>10215-Servo Link Ball End 6pcs</p> 	<p>10216-Steering Linkage Ball End 6pcs</p> 

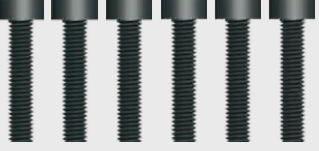
Part List

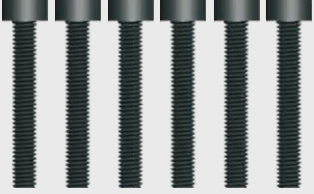
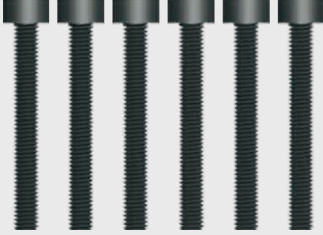
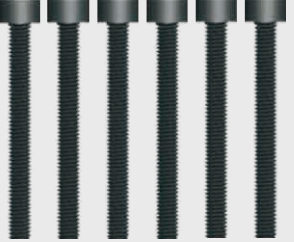
<p>10217-Rear Upper Linkage Ball End 6pcs</p> 	<p>10218-Sway Bar Fix Plate 6pcs</p> 	<p>10219-Sway Bar Holders 6pcs</p> 	<p>10220-Ball A 6pcs</p> 
<p>10221-Ball B 6pcs</p> 	<p>10222-Ball C 6pcs</p> 	<p>10223-Ball D 6pcs</p> 	<p>10224-Shock O-ring(Lower) 6pcs</p> 
<p>10225-Diff O-ring Seal 6pcs</p> 	<p>10226-Shock Seal Cover 4pcs</p> 	<p>10227-Tuned Pipe Seal & Fuel Tank Seal 1set</p> 	<p>10228-Pin ϕ 2*10 6pcs</p> 
<p>10229-Pin ϕ 2*11 6pcs</p> 	<p>10230-Hinge Pins(long & short) 2sets</p> 	<p>10231-One Way Bearing 3pcs</p> 	<p>10232-Ball Bearing 15*10*4 6pcs</p> 
<p>10233-Ball Bearing 10*5*4 6pcs</p> 	<p>10234-Metal Bushing 10*5*4 6pcs</p> 	<p>10235-Ball Bearing 8*5*2.5 6pcs</p> 	<p>10236-E clip-8mm 4pc</p> 
<p>RH5190-E clip-4mm 6pc</p> 	<p>10237-E clip-2.5mm 6pc</p> 	<p>RH5102-Nylon Lock Nut M3 6pc</p> 	<p>RH5103-Nylon Lock Nut-M4 6pc</p> 

Part List

<p>85148-Round Head Self Tapping Hex Screw 2*6 4pcs</p> 	<p>10238-Round Head Self Tapping Hex Screw 2*10 6pc</p> 	<p>85179-Round Head Self Tapping Hex Screw 3*15 8pc</p> 	<p>10239-Round Head Self Tapping Hex Screw M3*6 6pc</p> 
<p>10240-Button Head Hex Screw M3*8 6pc</p> 	<p>10241-Button Head Hex Screw M3*10 6pc</p> 	<p>85184-Button Head Hex Screw M3*12 6pc</p> 	<p>10242-Button Head Hex Screw M3*14 6pc</p> 
<p>85144-Ring Self Tapping Screw 3*4 4pc 10256-Ring Self Tapping Screw 3*6 6pc</p> 	<p>RH5116-Set Screw M3*3 6pc</p> 	<p>RH5117-Set Screw M4*4 6pc</p> 	<p>RH5118-Button Head Hex Screw M4*10 6pc</p> 
<p>RH5562-Cap Head Hex Screw M3*8 6pc</p> 	<p>10243-Cap Head Hex Screw M3*10 6pc</p> 	<p>85182-Cap Head Hex Screw M3*10 6pc</p> 	<p>10244-Cap Head Hex Screw M3*14 6pc</p> 
<p>85119-Cap Head Hex Screw M3*16 6pc</p> 	<p>10245-Cap Head Hex Screw M3*18 6pc</p> 	<p>85185-Cap Head Hex Screw M3*25 6pc</p> 	<p>10246-Cap Head Hex Screw M3*28 6pc</p> 
<p>10247-Flat Head Hex M3*8 6pc</p> 	<p>85125-Flat Head Hex Screw M3*10 8pc</p> 	<p>85175-Flat Head Hex Screw 3*10 8pc</p> 	<p>10248-Flat Head Hex Screw M3*12 6pc</p> 

Part List

<p>10249-Flat Head Hex Screw M3*14 6p</p> 	<p>85127-Flat Head Hex Screw M3*18 3p</p> 	<p>10250-Flat Head Hex Screw M3*20 6p</p> 	<p>10251-Flat Head Hex Screw M3*36 6p</p> 
<p>85173-Flat Head Hex Screw M4*10 6p</p> 	<p>H0068-2.4G FS GT2 TX+RX H0068RX-FS Gt2 RX 1pc</p> 	<p>RH5189 - Receiver Switch 1pc</p> 	<p>H0072-KS 45A brushless ESC H0082-KS 60A brushless ESC</p> 
<p>H0050-40A brushed ESC</p> 	<p>H0028-3650 3000kv Brushless Motor 1pc H0085-3650 3800kv Brushless Motor 1pcs</p> 	<p>H0029 - 550 Brushed Motor 1pc</p> 	<p>H0030 - Ni-MH 7.2V 1800mAh 1pc H0031 - Ni-MH 7.2V 3000mAh 1pc</p> 
<p>H0012 - Battery Case 1pc</p> 	<p>H0049-3kg/cm Servo 1pc</p> 	<p>85274-Li-Po 2700mAh 7.4V 1pc</p> 	<p>10253 - 1/10 Charger CE 1pc 10254 - 1/10 Charger UL 1pc 10255 - 1/10 Charger BS 1pc</p> 
<p>85284-Battery case 1pc</p> 	<p>85285-RX case 1set</p> 	<p>10609-Flat Hex Screw M3*40 6pcs</p> 	<p>10610-Rear bumper fix plate & susp. arm pins set</p> 
<p>10626-Jeep rear body mount 2pcs</p> 	<p>R0197-Clear SUV body 1pc R0188-Mat black SUV body 1pc</p> 	<p>R0164-Clear jeep body 1pc R0187-Mat black jeep body 1pc</p> 	

Upgrade Parts List

<p>10902 - Front Shock Plate (Carbon) 1Set</p> 	<p>10903 - Rear Shock Plate (Carbon) 1Set</p> 	<p>10907-Front Shocks (AL) 2pc</p> 	<p>10908-Rear Shocks (AL) 2pc</p> 
<p>10909 - Front Lower Susp. Arm (AL) 2pc</p> 	<p>10910 -Rear Lower Susp. Arm (AL) 2pc</p> 	<p>10911 - Steering Ackerman (AL) 1pc</p> 	<p>10912 - Front Susp. Holders (AL) 1Set</p> 
<p>10913 - Front & Rear Brace(AL) (AL) 1Set</p> 	<p>10914 - Rear Susp. Holders (AL) 1Set</p> 	<p>10915 - Rear Hub Carrier (AL) 2pc</p> 	<p>10916-Front Top Plate (Carbon) 1pc</p> 
<p>10917 - Steering Knuckle Arm (AL) 2Set</p> 	<p>10918 - Wheel Hub (AL) 4pc</p> 	<p>10919 - Upper Plate(AL) 1pc</p> 	<p>10920 - Tuned Pipe(AL) 1Set</p> 
<p>10921 - Chassis Brace mount (AL) 1pc</p> 	<p>85265 - Heatsink 1pc</p> 	<p>10923 - Alum Steering Arm 2pc</p> 	<p>10924 - Alum Knuckle Arm 2pc</p> 
<p>10969-Alloyfront suspension holders 1set</p> 	<p>10970-Alloy rear susp. holders 1set</p> 		